

# ALLFETT®

CENTRAL LUBRICATION SYSTEMS & EQUIPMENT



**ALL-1** Heavy Industry Type  
**ELECTRICAL GREASE PUMPS**

## INTRODUCTION AND USER MANUAL

VERSION 2.00

THE PHYSICAL LIFE DETERMINED BY MINISTRY OF INDUSTRY AND TRADE  
OF TURKEY IS 10 YEARS.

## INTRODUCTION

All industrial machinery, equipments and vehicles are working under abrasive operating conditions. The wear between frictional parts become the most highest level at these conditions. Machinery expose bad weather, dust, dirt, rain, snow and heavy weight in most cases. Consequently unwanted breakdowns occur and by that way productivity loss is inevitable.

Using automatic lubrication system only increase your profitability. ALLFETT completely take over the work load spend on lubrication with a system which is bringing together a pump, control unit, distributors, tubes and couplings. Lubrication work is done by ALLFETT centralized lubrication systems in efficient time of machinery or vehicle which is while operating.

Lubrication is important for all frictional parts but using correct lubrication system and method only protect parts from wearing for a long time. Feeding lubrication points with correct dosage of lubricant at certain intervals while machinery is operating, provides lubricant film in place longer between parts. By ALLFETT lubrication systems life time of parts on your machinery and vehicles will be increased.

## ABOUT MANUFACTURER

With over 25 years experience of manufacturing Centralized Lubrication Systems ALLFETT is able to provide a wide professional approach to select the correct Centralized Lubrication System for industry and heavy machinery.

A highly accurate manufacturing process is involved in producing Centralized Lubrication Systems in order that systems meet the very tight quality procedures and state of the art processes are employed. ALLFETT is among the few companies whose products meet the exact technical and quality standards for a correct central lubrication. We present our high quality and advanced product design concept to our worldwide costumers through our strong brand.

ALLFETT creates new opportunities and innovative solutions. As a result of the satisfaction of our customers with our good quality lubrication systems we are continuing in growing in the local and international market and became one of the successful companies in the field.

## WARNINGS

Symbols and words shown below are meant to warn a particular risk to persons, material assets, or the environment. Please carefully read this manual before installing. Failure to follow the instructions and safety precautions in this manual could result in serious injury or property damage.

**Caution****Notice****Electricity****Prohibition**

## CONTENTS

INTRODUCTION _____	PAGE <b>1</b>
CONTENTS _____	PAGE <b>2</b>
PRODUCT DESCRIPTION AND GENERAL SPECIFICATIONS _____	PAGE <b>3</b>
PRODUCT DIMENSIONS _____	PAGE <b>4</b>
PRODUCT COMPONENTS _____	PAGE <b>5</b>
FUNCTION _____	PAGE <b>6</b>
PUMP ELEMENT DESCRIPTION _____	PAGE <b>7</b>
LUBRICANT INFORMATION _____	PAGE <b>8 - 9</b>
ELECTRICAL CONNECTION _____	PAGE <b>10</b>
RULES TO COMPLY WHILE USING AND WARRANTY CONDITIONS _____	PAGE <b>11 - 12</b>
PUMP MAINTENANCE _____	PAGE <b>13</b>
PUMP ELEMENT MAINTENANCE _____	PAGE <b>14</b>
ORDER INFORMATION _____	PAGE <b>15</b>
WARRANTY _____	PAGE <b>16</b>
WARRANTY CONDITIONS _____	PAGE <b>17</b>
TRANSPORT AND STORAGE _____	PAGE <b>18</b>

## PRODUCT DESCRIPTION

ALL-1 electrical grease pumps are manufactured only for lubrication purpose. Pump displacement is various to provide required lubrication needs. Optionally obtained pump element(s) creates pressurized grease out with different displacement volumes. 1 and up to 6 pump elements can be added on pump body.

The pump reservoir is manufactured from transparent polycarbonate to allow user easily check the level of grease. In case the pump is installed so that operator cannot see the level of grease the ALLFETT low level sensor can be used to follow the level of grease. Top filling application is possible with different filling covers, with or without lock.

ALL-1 pumps can be controlled and monitored with integrated electronic control cards. Optional control card feature also displays warnings as broken fuse, fault and alarms.

## GENERAL SPECIFICATIONS

<b>Motor type</b>	: 12 - 24 V DC
<b>Working pressure</b>	: 400 bar.
<b>Motor protection class</b>	: IP 54
<b>Grease type</b>	: NLGI 00 (-30°C) - (-10°C) NLGI 0 (-10°C) - (0°C) NLGI 1 (0°C) - (10°C) NLGI 2 (10°C) - (30°C) NLGI 3 (30°C +)
<b>Working temperature</b>	: -25°C +80°C
<b>Reservoir capacities</b>	: 14 Liters

## OPTIONAL SPECIFICATIONS

<b>Pump elements</b>	: 1 - 6
<b>Pump element displacement</b>	: (Ø5) 1.5cm <sup>3</sup> / minute (Ø6) 2.5cm <sup>3</sup> / minute (Ø7) 3.5cm <sup>3</sup> / minute



**ALL-1 pums are manufactured only lubrication purpose. It is not convenient to run these pumps more than 2 hours continuously.**

## PRODUCT DIMENSIONS

Technical drawings below represents the ALL-1 pump general dimensions.

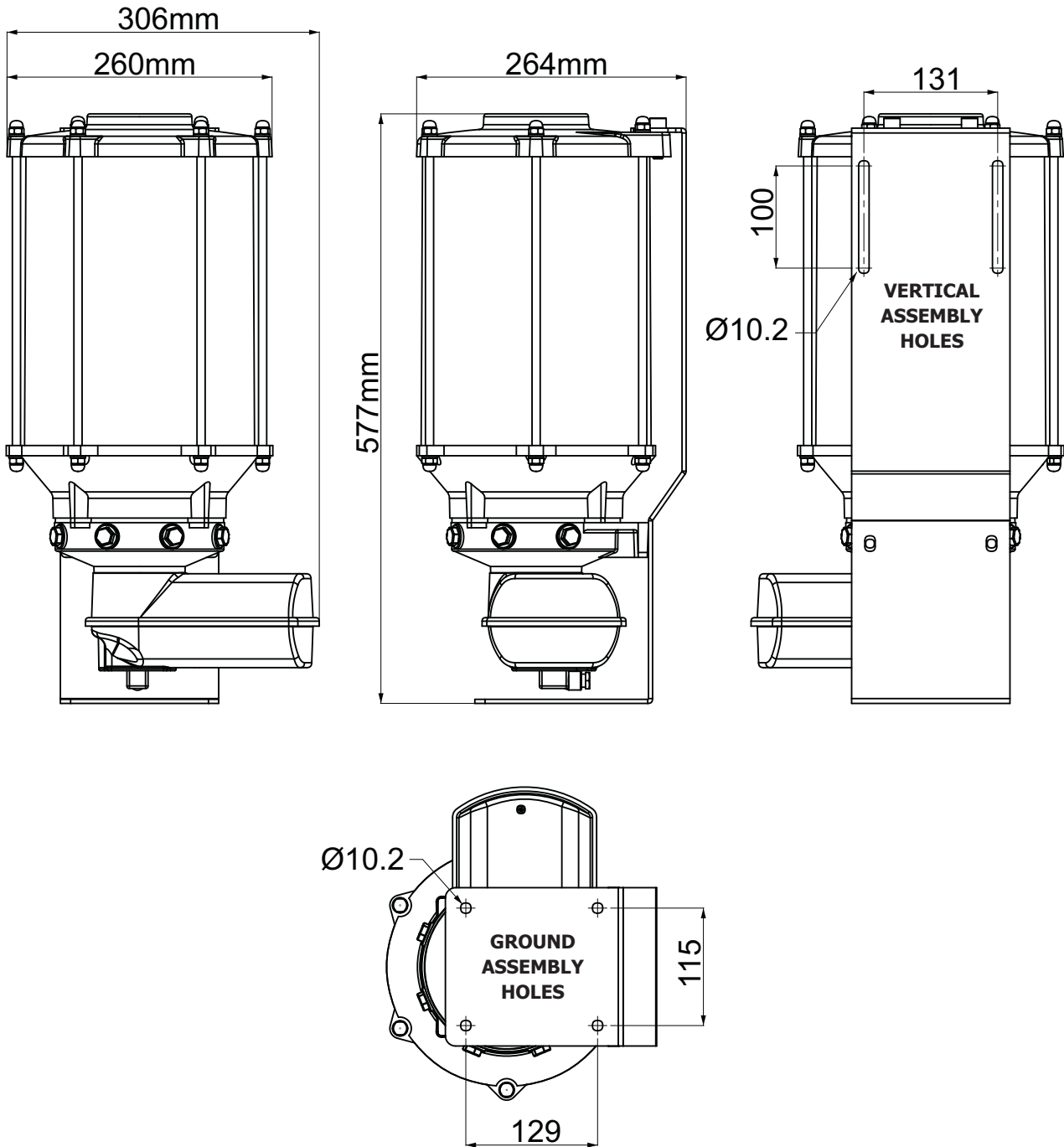

## PRODUCT COMPONENTS

Technical drawings below represents the ALL-1 pump components. Optional specifications described seperately.

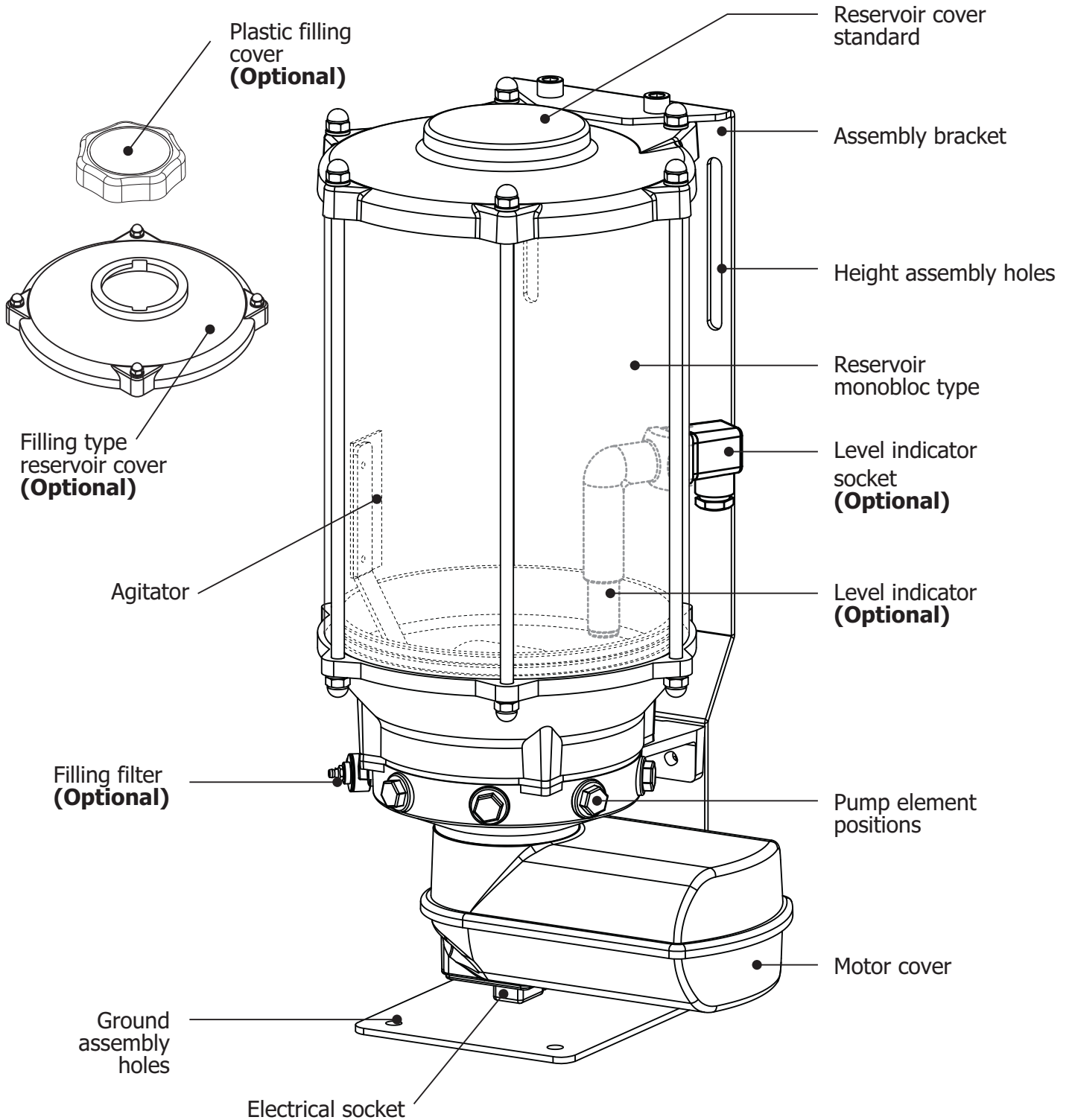

## FUNCTIONAL DESCRIPTION

Appropriate electrical energy (12 or 24 V DC ) is connected to system ;

Electrical motor start to operate and agitator inside reservoir rotates clockwise.

Spring returned pump element piston vacuums the lubricant inside reservoir. Rotational movement of the eccentric pushes pump element piston so that the lubricant vacuomed before is sended to pump element outlet with high pressure. Working pressure can be adjusted on security valve.

The lubricant coming out from pump elements ;

Displacement volume of the pump element(s) can be connected to single lubrication point. However displacement volume can also be divided by progressive distributor to feed multiple lubrication points.

Optional system control units ;

Lubrication system and its components can be controlled and monitored with integrated electronic control cards. Digital sensores and also pressure switches where placed on system components send information to control card.



**Pump elements, distributors and control cards are offered optionally. While ordering a pump, other components have to be ordered separately according to their properties.**

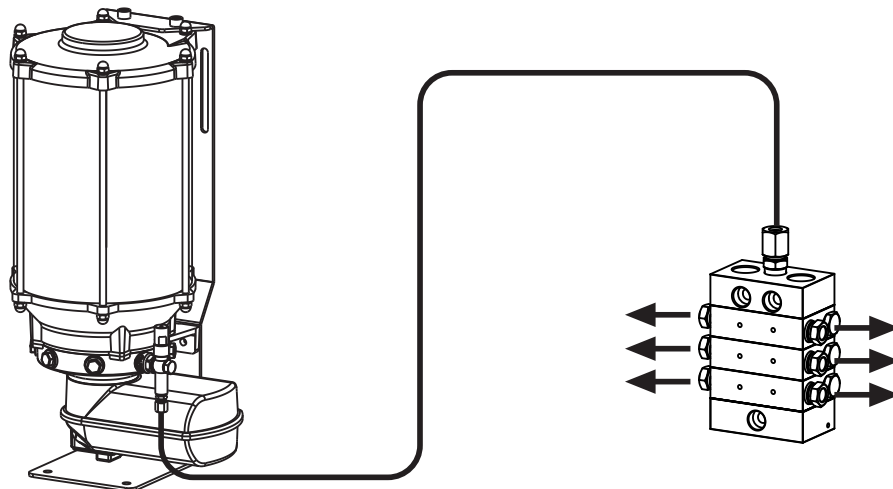

**Any maintenance on ALL-1 pumps under electrical voltage could lead to personal injury. Disconnect all electrical power before any maintenance .**



**Any maintenance on ALL-1 pumps under high pressure could lead to personal injury. Discharge the system pressure before any maintenance .**



**Unauthorized modifications to the units and the use of unauthorzied spare parts and aids prohobited also disqualify the warranty.**

## PUMP ELEMENT DESCRIPTION

ALL-1 grease pumps are available in several displacement volumes. These volumes can be created with pump elements which are optionally offered. 1 to 6 Pump elements can be applied onto ALL-1 pump body to take grease out. Even though single pump element can be used as outlet, multiple pump elements can be bridged as single outlet to get more displacement.

Pump element is equipped with security relief valve to protect any damage may occur from high pressure. Lubrication system pressure is increasing when a lubrication point is blocked. Up to 450 bar. pressure, lubrication system's working pressure can be adjusted by security relief valve. Lubricant with over pressure will be out from exhaust hole.

Pump elements are manufactured in 3 types according to displacement amounts. These types can be described as its piston diameter ;

- with Ø5 mm piston, pump element's outlet displacement is 1.5cm<sup>3</sup> / minute
- with Ø6 mm piston, pump element's outlet displacement is 2.5cm<sup>3</sup> / minute
- with Ø7 mm piston, pump element's outlet displacement is 3.5cm<sup>3</sup> / minute

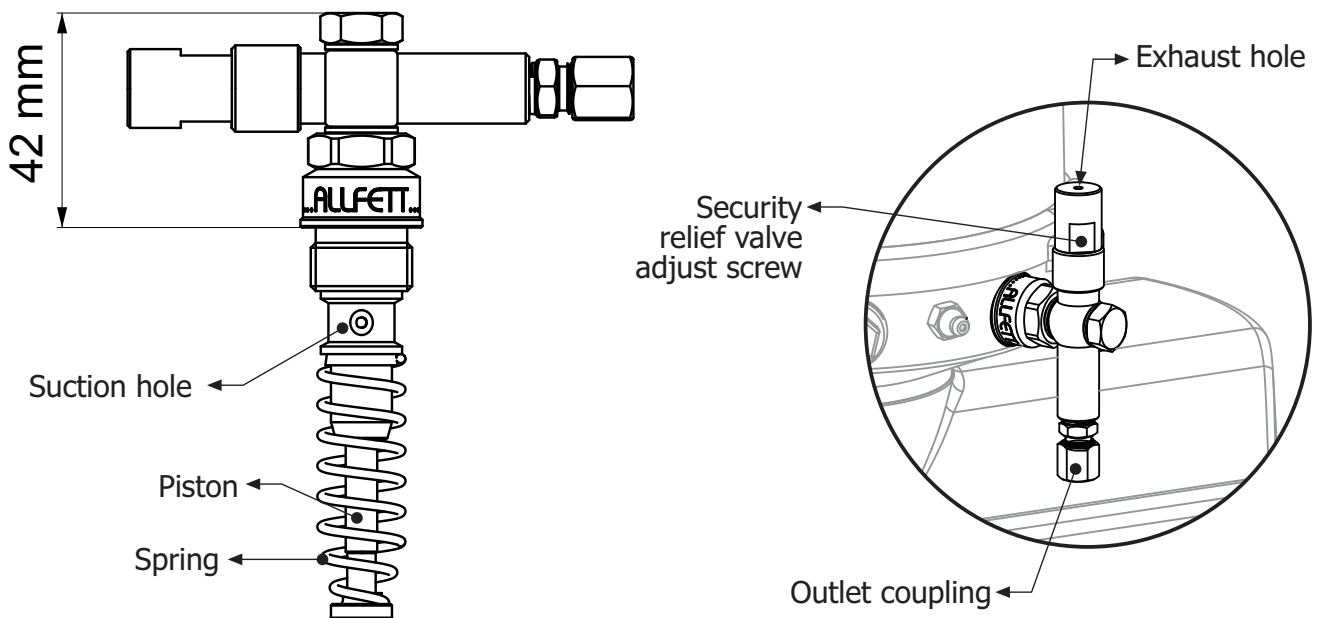

**Pump elements are offered optionally. When ordering a pump, pump elements have to be ordered separately according to displacement properties.**



## LUBRICANT INFORMATION

Lubricant specifications can be used with ALL-1 pumps are described below. Before filling reservoir please read carefully these informations.



**Lubricant will be used in the system must certainly be clean and any foreign materials must not enter while filling.**



**ALL-1 pumps are designed to use with in centralized lubrication systems only. It is not suitable to use ALL-1 pump for lubricant tranfering or circulation purpose.**



**To remind that lubricants has content which may hazardous to environment. It is important that the county specific regulations and laws on the use and disposal of lubricants must be observed.**

### Lubricant type - GREASE

NLGI classes can be used with ALL-1 pumps are described below. Because of the flow characteristics of grease the NLGI class range should be changed at different weather conditions and also temperature differencies.

for **NLGI 00** grease recomended working temperature is between -30°C and -10°C

for **NLGI 0** grease recomended working temperature is between -10°C and 0°C

for **NLGI 1** grease recomended working temperature is between 0°C and 10°C

for **NLGI 2** grease recomended working temperature is between 10°C and 30°C

for **NLGI 3** grease recomended working temperature is 30°C and over



**Keep in mind that the substances of any lubricant are harmful to environment. Their transport and storage require that special safety measures be taken.**



**Only LITHIUM based and EP additive liquid greases must be used with in system.**

It is important that the grease will be used must resistant to high pressure. Make sure the liquid grease you are using is EP additive.



**Do not use rubber based grease in system.  
Do not use grease types with graphite in system.**

## LUBRICATION INFORMATION

Grease penetration properties is variable at different environment temperatures. The environmental temperature around lubrication lines must be considered for choosing the correct grease. Grease properties should be appropriate that environmental temperatures. Changing NLGI classes at different temperatures is important to correct lubrication. If necessary, high temperature resistant lubricants should be used in some cases.



**It should not be forgotten that the grease penetration properties is variable at different environment temperatures.**

## PRESSURE LOSE CHART

Loosing pressure in lubrication lines depends on differend variables. The most important variables are pump displacement, environmental temperatures, tube diameter and NLGI class. Each variable must be considered for correct lubrication.

The chart below represents the approximate pressure loose in tube which 1 meter long. Results are varies according to pump element displacement volume created by single or multiple pump elements. Result values are defined in bar.

Tube diameter	Lubricant class	Single Ø6 mm pump element					3 piece Ø6 mm pump element					6 piece Ø6 mm pump element				
		2,5 cm <sup>3</sup> / minute					7,5 cm <sup>3</sup> / minute					15 cm <sup>3</sup> / minute				
		-10°C	0°C	10°C	20°C	30°C	-10°C	0°C	10°C	20°C	30°C	-10°C	0°C	10°C	20°C	30°C
Ø6 x 1 (Ø6mm)	NLGI 0	4,8	2,6	1,4	0,78	0,48	7,8	4,2	2,4	1,44	0,84	9,6	5,1	3	1,8	1,14
	NLGI 1	8	4,4	2,4	1,3	0,8	13	7	4	2,4	1,4	16	8,5	5	3	1,9
	NLGI 2	12,8	7	3,8	2	1,28	20,8	11,2	6,4	3,84	2,24	25,6	13,6	8	4,8	3
Ø8 x 1 (Ø6mm)	NLGI 0	2,7	1,32	0,72	0,42	0,24	3,9	2,1	1,14	0,66	0,42	4,8	2,7	1,56	0,9	0,54
	NLGI 1	4,5	2,2	1,2	0,7	0,4	6,5	3,5	1,9	1,1	0,7	8	4,6	2,6	1,5	0,9
	NLGI 2	7,2	3,52	1,92	1,12	0,64	10,4	5,6	3	1,76	1,12	12,8	7,3	4,16	2,4	1,44
Ø10 x 1 (Ø8mm)	NLGI 0	1,44	0,72	0,36	0,21	0,12	2,16	1,1	0,6	0,3	0,18	2,64	1,8	0,78	0,42	0,25
	NLGI 1	2,4	1,2	0,6	0,35	0,2	3,6	1,8	1	0,5	0,3	4,4	2,3	1,3	0,7	0,42
	NLGI 2	3,84	1,92	0,96	0,56	0,32	5,76	2,88	1,6	0,8	0,48	7	3,68	2	1,12	0,67
Ø12 x 1 (Ø10mm)	NLGI 0	0,96	0,45	0,22	0,12	0,06	1,32	0,66	0,36	0,18	0,1	1,62	0,84	0,45	0,25	0,15
	NLGI 1	1,6	0,75	0,38	0,2	0,1	2,2	1,1	0,6	0,3	0,18	2,7	1,4	0,75	0,42	0,26
	NLGI 2	2,56	1,2	0,61	0,32	0,16	3,52	1,76	0,96	0,48	0,29	4,32	2,24	1,2	0,67	0,42
R 1/2 (Ø15,75mm)	NLGI 0	0,45	0,2	0,09	-	-	0,6	0,27	0,12	0,07	-	0,69	0,33	0,16	0,09	-
	NLGI 1	0,75	0,34	0,16	-	-	1	0,45	0,2	0,12	-	1,15	0,55	0,28	0,16	-
	NLGI 2	1,2	0,54	0,26	-	-	1,6	0,72	0,32	0,19	-	1,84	0,88	0,45	0,26	-
R 3/4 (Ø21,25mm)	NLGI 0						0,33	0,15	0,06	-	-	0,39	0,16	0,1	-	-
	NLGI 1						0,55	0,25	0,1	-	-	0,65	0,28	0,18	-	-
	NLGI 2						0,88	0,4	0,16	-	-	1	0,45	0,29	-	-
R 1 (Ø27mm)	NLGI 0											0,24	0,12	0,09	-	-
	NLGI 1											0,4	0,2	0,16	-	-
	NLGI 2											0,64	0,32	0,26	-	-

## ELECTRICAL CONNECTIONS

Pumps have an electric driven motor. Electrical lines must be connected properly as described in schema below. Electrical socket is placed under motor cover.



**Transformer is necessary if there is no " 24 V DC " power source. Use minimum 5A current transformer.**

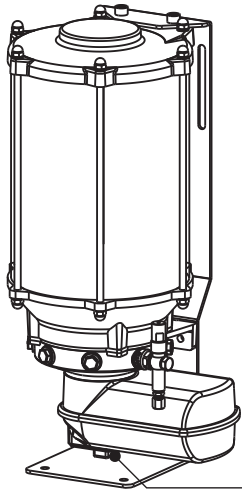

→ Electrical socket

Electrical socket

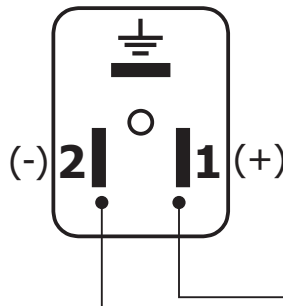

12 - 24 V DC  
POWER SUPPLY

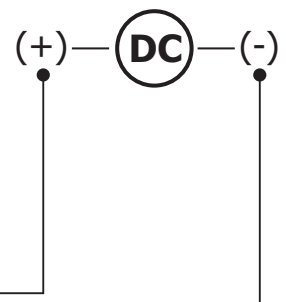

**Any maintenance on ALL-1 DC pumps under electrical voltage could lead to personal injury. Disconnect all electrical power before any maintenance .**

If ALL-1 DC pump will be used with ALLFETT **EK-9** external control card, electrical lines must be connected properly as described in schema below.

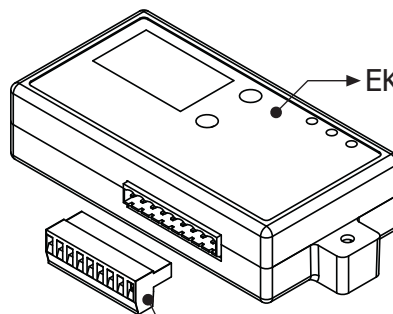

→ EK-9 external control card

ALL-1 Pump  
Electrical socket

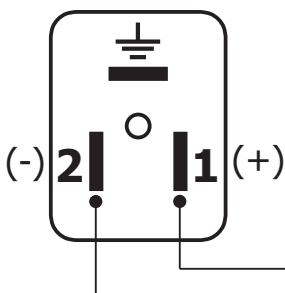

EK-9 Control card socket

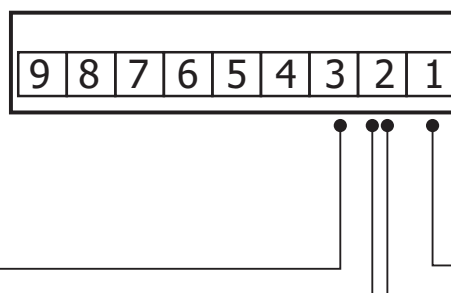

12 - 24 V DC  
POWER SUPPLY

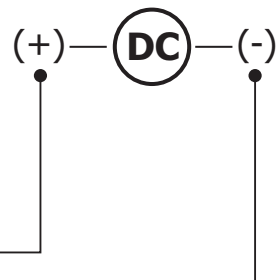

## **RULES TO COMPLY WHILE USING AND WARRANTY CONDITIONS**

- 1.** Damages occur while additional transports after delivering the goods from ALLFETT to the customer **DISQUALIFIES THE WARRANTY.**
- 2.** Pumps are produced to lubrication purpose only and are not convenient to work more than 2 hours continuously. Working under maximum pressure more than 2 hours will harm the system. Damages occur from this reason **DISQUALIFIES THE WARRANTY.**
- 3.** Washing of the pump with pressured water causes damage. Any damage occur from this reason **DISQUALIFIES THE WARRANTY.**
- 4.** Pump reservoir is made of transparent material to see grease level. Painting any part of the pump is not recommended. Any painted parts **DISQUALIFY THE WARRANTY.**
- 5.** Pumps have an electric driven motor. Electrical lines must be connected properly as described in PAGE 10 - 11 and applied only by qualified and instructed personel.
- 6.** All electrical connections and lines must be checked regularly for damage and to ensure that they are firmly in place.
- 7.** Damages coming from voltage fluctuation, wrong electricity installation, connecting wrong voltage to product **DISQUALIFIES THE WARRANTY.**
- 8.** Keeping an uncovered cable(s) during system assembly may cause fatal damages where high voltage is transformed to low voltage. Lines must be connected properly to prevent personal injury and damage to property.
- 9.** Transformer is necessary if there is no " 24 V DC " electrical source. Use minimum 5A current transformer.
- 10.** Only proper NLGI class lubricants must be used with in system. NLGI class must be changed according to weather conditions. Use NLGI 0 for cold weather, increase the NLGI class up to 3 towards hot weathers.
- 11.** Only LITHIUM based and EP additive lubricants must be used with in system.
- 12.** Rubber based lubricant types must not be used in the system. Damages or faults occur from this reason **DISQUALIFIES THE WARRANTY.**
- 13.** Lubricant will be used in the system must certainly be clean and any foreign materials must not enter while filling.
- 14.** Any foreign materials, dirt or small particules while filling lead to system units failing and possibly property damage to equipments. Damages or faults occur from this reason **DISQUALIFIES THE WARRANTY.**
- 15.** Pump must be filled from the grease nipple. If grease level is lower than the minimum level (as you can not see grease level) grease nipple must be used to prevent air entrance inside the pomp body. Lockable filling cover option can only be used after filling pump from grease nipple up to minimum level.

## RULES TO COMPLY WHILE USING AND WARRANTY CONDITIONS

16. If lockable filling cover will be used to fill pump, environment must be clean to avoid any foreign materials entering to reservoir. Any foreign materials, dirt or small particules while filling lead to system units failing and possibly property damage. Damages or faults occur from this reason **DISQUALIFIES THE WARRANTY.**
17. If the pump works without lubricant, pump elements will send air to the points instead of grease. Because of that any points connected to pump will not get any lubricant. Damages on pump and on the system coming from that reason **DISQUALIFIES THE WARRANTY.**
18. Using ALL-1 pumps with integrated control card models, high frequency wireless comination devices 1 meter distance from the pump may cause malfunction. Damages or faults occur from this reason **DISQUALIFIES THE WARRANTY.**
19. Integrated control card works between 10 to 30 Voltage. Although there is a protection against high voltage, control card may be broken if connected to high voltage power source. Damages or faults occur from this reason **DISQUALIFIES THE WARRANTY.**
20. Disassembling or loosing any part while pump working is prohibited. Any damage coming from this reason **DISQUALIFIES THE WARRANTY.** Also any personal injury occur from this reason ALLFETT does not accept responsibility.
21. Another goal of Centralized Lubrication Systems is to protect environment. So it is adviced to fill grease to the systems by mobile or hand pumps.
22. Unauthorized modifications to the units and the use of unauthorzied spare parts and aids prohobited and **DISQUALIFIES THE WARRANTY.** Only maintenance may apply descibed in PAGE 14 - 15. ALLFETT Technical Service must be informed to any other possible troubles and necessary procedures must be performed.
23. ALLFETT Mekanik ve Elektronik Sistemler SAN. TIC. LTD. STI and ALLFETT Pazarlama ve Dis Ticaret LTD. STI. does not accept responsibility for damages described in items above on equipments which ALLFETT systems are installed.

## QUALITY SYSTEM



This product is produced by **ALLFETT Mekanik ve Elektronik Sistemler San. Tic. Ltd. Sti.** company, which, is certificated by Bureau Veritas with certificate to compatible for ISO 9001:2008 standard and owner of the quality management system.

## PUMP MAINTENANCE

### 1. IF PUMP NOT STARTS

- a. Electrical connections of the pump may be loosen or broken. Check the electrical cables and connections of the system according to schemas on page 9 and page 10.
- b. Connected electricity to pump may different then " DC " voltage. Connect the electricity 12 or 24 V DC which is marked on pump sticker.
- c. Connected electricity may be converted to "DC" voltage from "AC" voltage by a transformer.

Transformer must be minimum 5A current.

- d. If pump has low level indicator ;

Control unit (PLC or integrated control card) may give failure and stops the pump because of the grease inside pump decreased under minimum level. Fill the reservoir according to items 10, 11, 12, 13, 14, 15 and 16 in RULES TO COMPLY WHILE USING AND WARRANTY CONDITIONS.

- e. If ALLFETT control card is connected the system ;

Electronic control card may be in waiting period. Wait until working time starts.

If necessary control card pass to working period by pressing **ADDITIONAL CYCLE** button.

### 2. IF PUMP NOT SENDING GREASE

- a. Grease inside pump decreased under minimum level. Fill the reservoir according to items 10, 11, 12, 13, 14, 15 and 16 in RULES TO COMPLY WHILE USING AND WARRANTY CONDITIONS.
- b. Pump elements may take air due to work without grease ;

Read and apply PUMP ELEMENT MAINTENANCE information on page 14.



**Unauthorized modifications to the units and the use of unauthorized spare parts and aids prohibited and disqualify the warranty.**

## TECHNICAL SERVICE

**ALLFETT MEKANİK VE ELEKTRONİK SİSTEMLER SAN. VE TİC. LTD. ŞTİ.**  
Yeni Eyüp Bulvarı, Topçular Caddesi, Set Üstü, No:1 Demirkapı-Rami / İstanbul  
Telefon: 0 212 501 32 01 (PBX) www.allfett.net  
Fax : 0 212 501 33 37 info@allfett.net

## PUMP ELEMENT MAINTENANCE

First use of the pump after filling reservoir, air must be sent out from pump element(s). To do this operation please read description below ;



**Filling the pump must be done by grease nipple on pump body.**

Remove connected tube from pump element's outlet coupling. Loosen pump element from pump body for 2 - 3 turns. Start to operate pump. When grease coming from around pump element body, tighten again pump element body to pump. Pump should run continuously until grease without air is seen from pump element outlet. When the grease without air is seen from pump element outlet, coupling must be tightened to outlet again

With this process pump element is now ready to send grease to lubrication point. Grease coming out from end point of lubrication line may take long time according to line length.

### If problems may appear while operate ;

- a. Pump element's piston spring may be broken. Remove the pump element and spring carefully. Pay attention spring does not fall into body. Change the spring if necessary.
- b. Pump element's piston may be blocked. Remove the pump element and clean with diesel based liquid. Assemble it to the pump body after drying with pressurized air.
- c. Sealing ring inside the pump element's check-valve may be worn or damaged. Change the sealing ring.
- d. Grease may be seen coming out from the security valve discharge. This means there is a blockage in lubrication point or distributor connected to this pump element. Blockage may cause the system to reach very high pressures and cause explosion of the lubrication lines. Blockage must be identified and fixed.

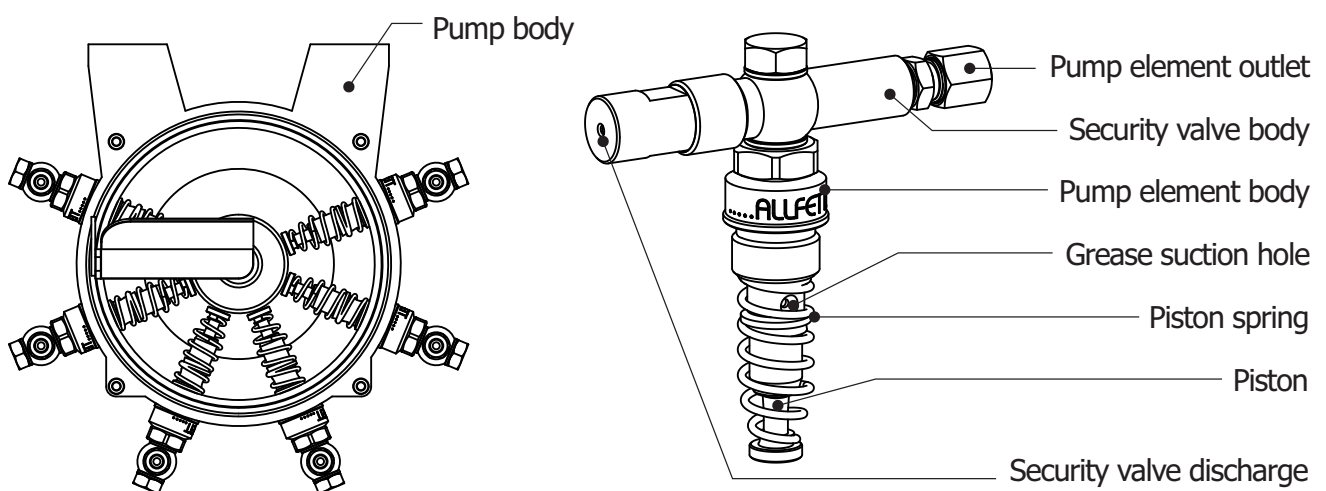

**ALL-1 pump body is suitable for 1 and up to 6 pump elements.**

## ORDER INFORMATION

<b>Product name - Description</b>	<b>Ordering number</b>
ALL-1 - 12 V DC - 14 Lt. - standard type	<b>10 12 14 A1</b>
ALL-1 - 12 V DC - 14 Lt. - filling type	<b>11 12 14 A1</b>
ALL-1 - 24 V DC - 14 Lt. - standard type	<b>10 24 14 A1</b>
ALL-1 - 24 V DC - 14 Lt. - filling type	<b>11 24 14 A1</b>

## OPTIONAL COMPONENTS

<b>Product name - Description</b>	<b>Ordering number</b>
ALL-1 Pump element - Ø5	<b>10 00 05 02</b>
ALL-1 Pump element - Ø6	<b>10 00 06 02</b>
ALL-1 Pump element - Ø7	<b>10 00 07 02</b>
Filling filter - Type Small	<b>10 0260</b>
Filling filter - Type Big	<b>10 0261</b>
Motor - 12 V DC	<b>10 12 MT 01</b>
Motor - 24 V DC	<b>10 24 MT 01</b>

## SALES

---

**ALLFETT PAZARLAMA VE DIŐ TİCARET LTD. ŐTİ.**

Yeni Eyűp Bulvarı, Topçular Caddesi, Set Üstű, No:1 Demirkapı-Rami / İstanbul  
Telefon: 0 212 501 32 01 (PBX) [www.alfett.net](http://www.alfett.net)  
Fax : 0 212 501 33 37 [info@alfett.net](mailto:info@alfett.net)



## WARRANTY

Utilisation of this warranty certificate has been permitted by The Republic of Turkey, The Ministry of Industrial and Commerce, The general Administration of Protection of Consumer Right and Competition, in accordance with the law numbered 4077 .

### PRODUCER COMPANY

---

NAME : ALLFETT Mekanik ve Elektronik Sistemler  
San. ve Tic. Ltd. Şti.

CENTRAL ADDRESS : Yeni Eyup Bulvari, Topcular Cad. Set Ustu, No:1 Demirkapı-  
Rami / İstanbul

TELEPHONE : 0212 501 32 01 (PBX)

FAX : 0212 501 33 37

### AUTHORISED PERSON

---

SIGNATURE - STAMP : :

### PRODUCT

---

TYPE : Electrical grease pump

BRAND : ALLFETT

MODEL : ALL-1 Heavy industry type

SERIAL NUMBER : .....

DELIVERY DATE / PLACE : .....

WARRANTY : 2 years

REPAIR TIME : 30 days

### SALER COMPANY

---

NAME : .....

CENTRAL ADDRESS : .....

TELEPHONE : .....

FAX : .....

BILL DATE / NUMBER : .....

## WARRANTY CONDITIONS

1. The warranty period is two years from the date of delivery.
2. The product including all its components is under the warranty of our company.
3. In case of defects within the warranty period the period spent in repairing is added to the warranty period. The repairing period is maximum 30 days. This period starts from the date of delivery of the product to the services centers or to the seller, the agency the representative, the importer or the manufacturer of the product respectively, in case there are service centers.
4. In case the product has material, workmanship or manufacturing defects, the product will be repaired free of charge and expenses of any sort including labor, the value of the parts replaced or any our charges.
5. The product will be replaced free of charge;
  - If the product permanently disfunctions due to repeating the same defect more than four times within the warranty period
  - If the maximum period for repairing is exceeded.
  - If it is determined that the defect cannot be repaired by report written by the service, or in the absence of service centers, by the seller, agency, representative, importer or manufacturer of the product respectively.
6. The present warranty does not cover damages resulting from importer handling by deviating from the instructions in the manual.
7. General administration of protection of consumer rights and competition in the ministry of industry and commerce may be applied for problems concerning the warranty certificate.

## **DANGEROUS OR HARMFUL CONDITIONS TO ENVIRONMENTAL AND HUMAN HEALTH DURING USE**

All ALLFETT systems are producing according to relevant provisions of security regulations. There is no risk for environmental and human health during use.

## **TRANSPORT AND STORAGE**

There are no restrictions on transportation by land, air and sea. In general, products should be stored in a dry and dust-free environment. The storage temperatures are between -10°C and +40°C.

All products are packed with paper based support material to reduce damage. Upon receiving the package please check the items for possible damage.



**ALLFETT MEKANİK VE ELEKTRONİK SİSTEMLER SAN. VE TİC. LTD. ŞTİ.**

Topçular Mahallesi, Topçular Caddesi No:1/1 - Eyüp / İstanbul

Telefon : 0 212 501 32 01 (PBX)

[www.allfett.net](http://www.allfett.net)

Fax : 0 212 501 33 37

[info@allfett.net](mailto:info@allfett.net)