

ALLFETT®

CENTRAL LUBRICATION SYSTEMS & EQUIPMENT



ALL-1mini Standard
ALL-1mini With integrated controller
ELECTRICAL GREASE PUMPS

INTRODUCTION AND USER MANUAL

VERSION 2.60

THE PHYSICAL LIFE DETERMINED BY MINISTRY OF INDUSTRY AND TRADE
OF TURKEY IS 10 YEARS.

INTRODUCTION

All industrial machinery, equipments and vehicles are working under abrasive operating conditions. The wear between frictional parts become the most highest level at these conditions. Machinery expose bad weather, dust, dirt, rain, snow and heavy weight in most cases. Consequently unwanted breakdowns occur and by that way productivity loss is inevitable.

Using automatic lubrication system only increase your profitability. ALLFETT completely take over the work load spend on lubrication with a system which is bringing together a pump, control unit, distributors, tubes and couplings. Lubrication work is done by ALLFETT centralized lubrication systems in efficient time of machinery or vehicle which is while operating.

Lubrication is important for all frictional parts but using correct lubrication system and method only protect parts from wearing for a long time. Feeding lubrication points with correct dosage of lubricant at certain intervals while machinery is operating, provides lubricant film in place longer between parts. By ALLFETT lubrication systems life time of parts on your machinery and vehicles will be increased.

ABOUT MANUFACTURER

With over 25 years experience of manufacturing Centralized Lubrication Systems ALLFETT is able to provide a wide professional approach to select the correct Centralized Lubrication System for industry and heavy machinery.

A highly accurate manufacturing process is involved in producing Centralized Lubrication Systems in order that systems meet the very tight quality procedures and state of the art processes are employed. ALLFETT is among the few companies whose products meet the exact technical and quality standards for a correct central lubrication. We present our high quality and advanced product design concept to our worldwide costumers through our strong brand.

ALLFETT creates new opportunities and innovative solutions. As a result of the satisfaction of our customers with our good quality lubrication systems we are continuing in growing in the local and international market and became one of the successful companies in the field.

WARNINGS

Symbols and words shown below are meant to warn a particular risk to persons, material assets, or the environment. Please carefully read this manual before installing. Failure to follow the instructions and safety precautions in this manual could result in serious injury or property damage.

**Caution****Notice****Electricity****Prohibition**

CONTENTS

INTRODUCTION _____	PAGE 1
CONTENTS _____	PAGE 2
PRODUCT DESCRIPTION AND GENERAL SPECIFICATIONS _____	PAGE 3
PRODUCT DIMENSIONS _____	PAGE 4
PRODUCT COMPONENTS _____	PAGE 5
FUNCTION _____	PAGE 6
PUMP ELEMENT DESCRIPTION _____	PAGE 7
LUBRICANT INFORMATION _____	PAGE 8 - 9
ELECTRICAL CONNECTION of ALL-1 Standard _____	PAGE 10
ELECTRICAL CONNECTION of ALL-1 with Integrated control _____	PAGE 11
INTEGRATED CONTROL CARD DESCRIPTION _____	PAGE 12
INTEGRATED CONTROL CARD PROGRAMMING INSTRUCTIONS _____	PAGE 13
RULES TO COMPLY WHILE USING AND WARRANTY CONDITIONS _____	PAGE 14 - 15
PUMP MAINTENANCE _____	PAGE 16
PUMP ELEMENT MAINTENANCE _____	PAGE 17
ORDER INFORMATION _____	PAGE 18
WARRANTY _____	PAGE 19
WARRANTY CONDITIONS _____	PAGE 20

PRODUCT DESCRIPTION

ALL-1mini electrical grease pumps are manufactured only for lubrication purpose. Pump displacement is various to provide required lubrication needs. Optionally obtained pump element(s) creates pressurized grease out with different displacement volumes. 1 and up to 3 pump elements can be added on pump body.

The pump reservoir is manufactured from transparent polycarbonate to allow user easily check the level of grease. In case the pump is installed so that operator cannot see the level of grease the ALLFETT low level sensor can be used to follow the level of grease. Top filling application is possible with different filling covers, with or without lock.

ALL-1mini pumps can be controlled and monitored with integrated electronic control cards. Optional control card feature also displays warnings as broken fuse, fault and alarms.

GENERAL SPECIFICATIONS

Motor type	: 12 - 24 V DC
Working pressure	: 400 bar. (with single pump element) 200 bar. (with 3 pump elements)
Motor protection class	: IP 54
Grease type	: NLGI 00 (-30°C) - (-10°C) NLGI 0 (-10°C) - (0°C) NLGI 1 (0°C) - (10°C) NLGI 2 (10°C) - (30°C) NLGI 3 (30°C +)
Working temperature	: -25°C +80°C
Reservoir capacities	: 1 - 1,8 Liters

OPTIONAL SPECIFICATIONS

Pump elements	: can be added 1 up to 3 pieces
Pump element displacement	: (Ø5) 1.5cm ³ / minute (Ø6) 2.5cm ³ / minute (Ø7) 3.5cm ³ / minute
Control card protection class	: IP 65
Control card voltage	: 10 - 30 V DC
Working time period	: Adjustable between 1 second to 99 minutes
Waiting time period	: Adjustable between 1 second to 99 hours
Warnings	: Broken fuse, Fault, Alarm



ALL-1 pums are manufactured only lubrication purpose. It is not convenient to run these pumps more than 2 hours continuously.

PRODUCT DIMENSIONS

Technical drawings below represents the ALL-1 pump models which has different reservoir capacities. Dimension unit is millimeter.

ALL-1 mini standard type pump.

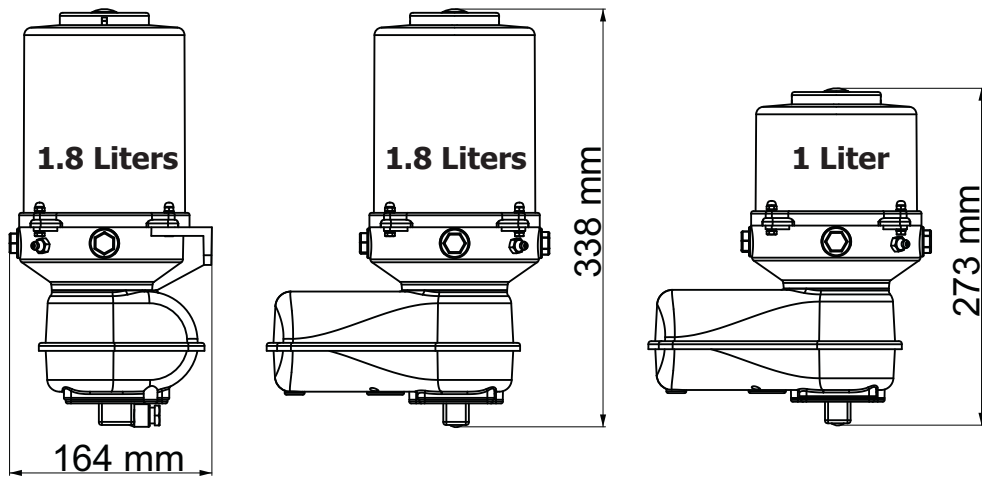

ALL-1 mini integrated control type pump.

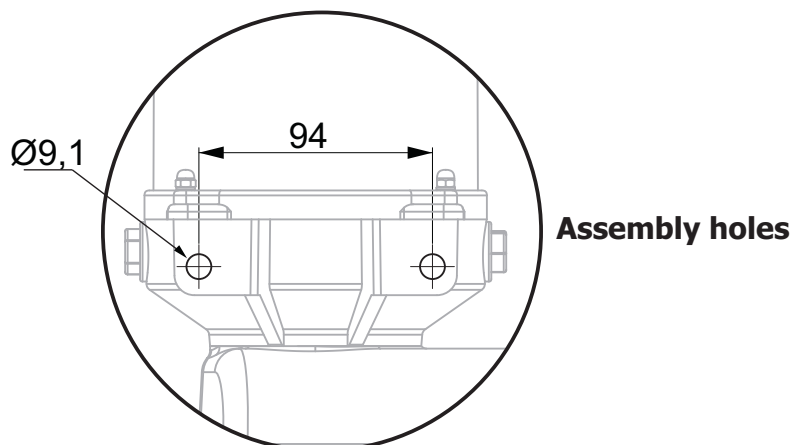
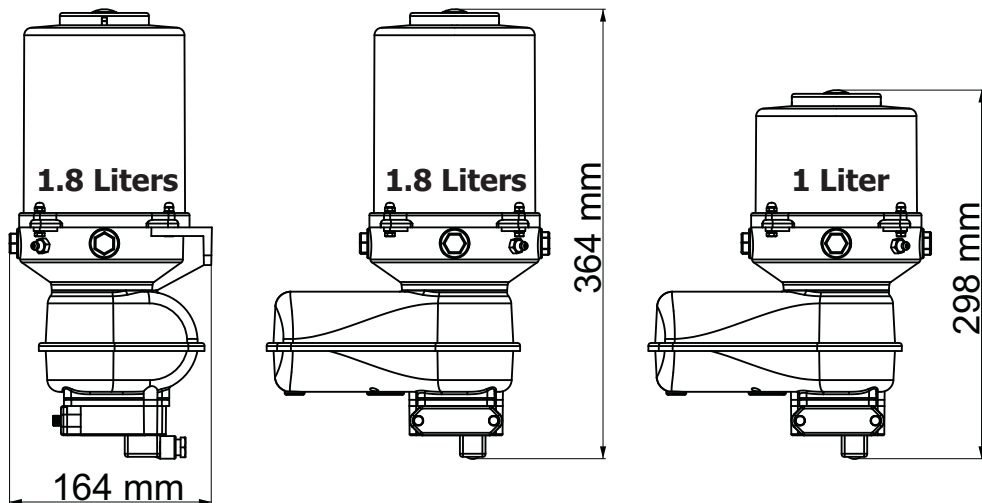

PRODUCT COMPONENTS

Technical drawings below represents the ALL-1mini pump's standard model and ALL-1mini Pump with integrated control model. Optional specifications described separately.

ALL-1 with integrated control

ALL-1 Standard

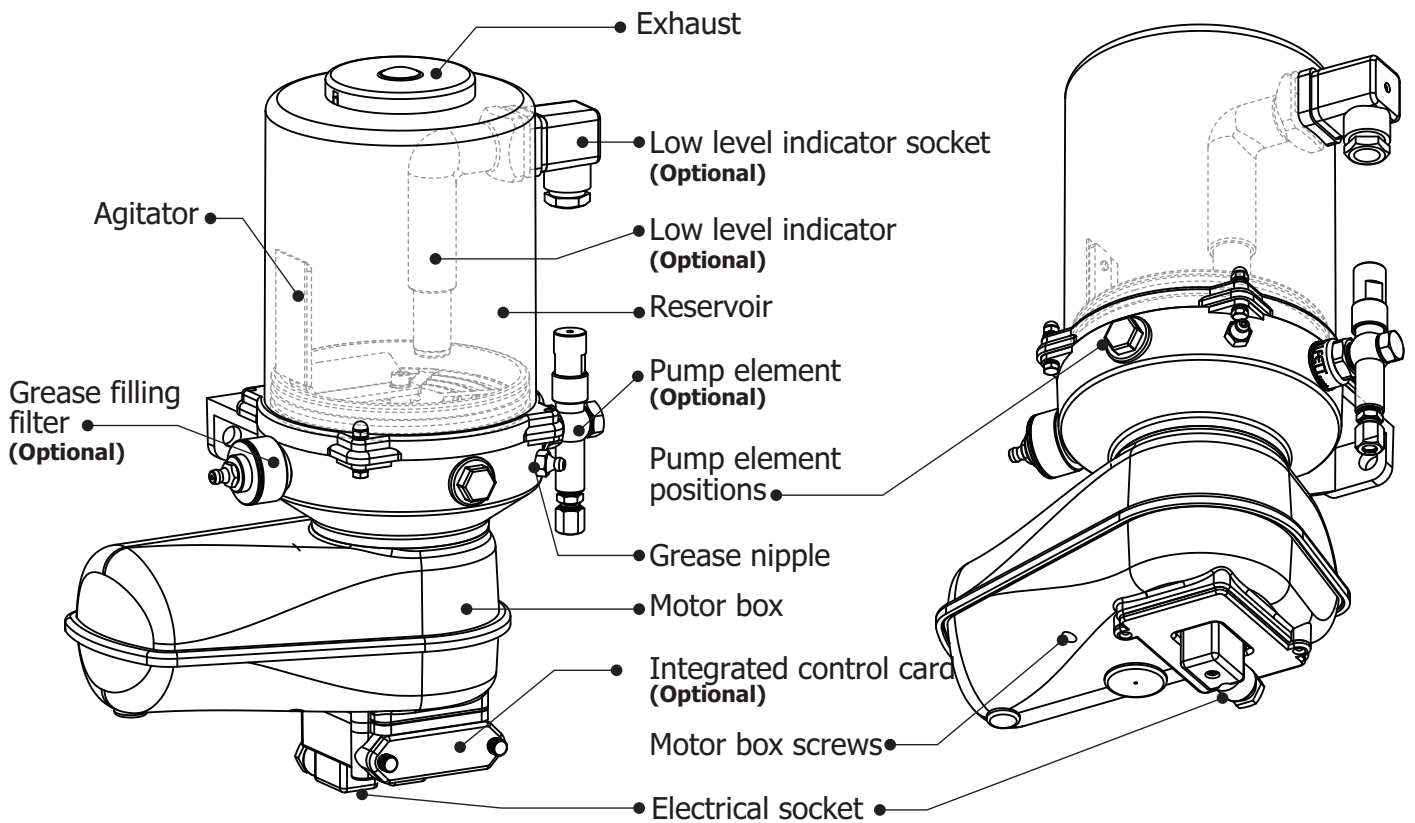

INTEGRATED CONTROL CARD COMPONENTS



Integrated control card is optional. Not presented onto standard type ALL-1mini pumps.

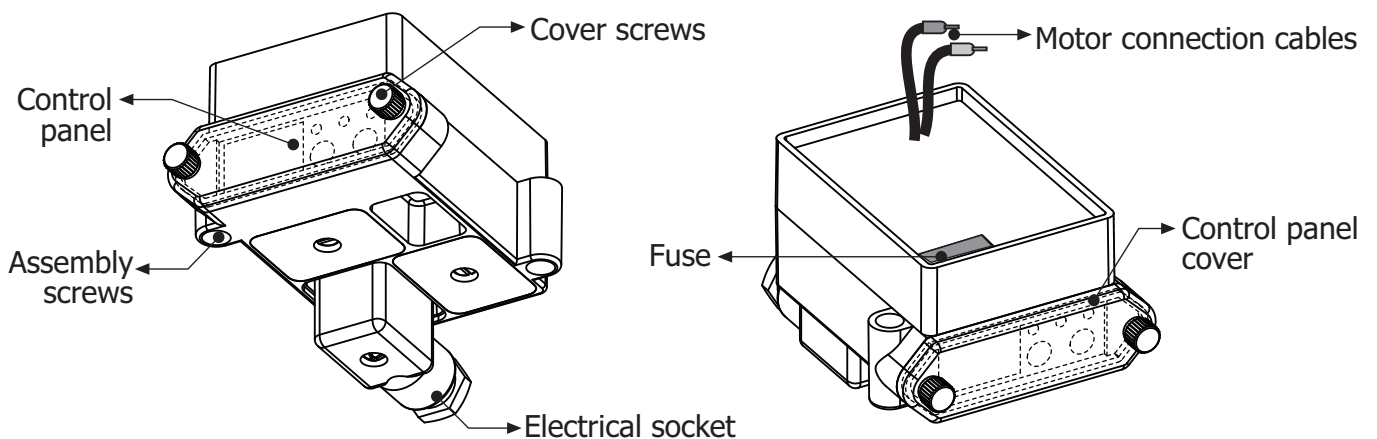

FUNCTIONAL DESCRIPTION

Along with " DC " voltage electrical energy connected to ALL-1 pump filled with grease ;

Electrical motor start to operate and agitator inside reservoir rotates clockwise.

Spring returned pump element piston vacuums the lubricant inside reservoir. Rotational movement of the eccentric pushes pump element piston so that the lubricant vacuomed before is sended to pump element outlet with high pressure. Working pressure can be adjusted on security valve.

The lubricant coming out from pump elements ;

Displacement volume of the pump element can be connected to single lubrication point. However displacement volume can also be divided by progressive distributor to feed multiple lubrication points.

Optional system control units ;

Lubrication system and its components can be controlled and monitored with integrated electronic control cards. Digital sensores and also pressure switches where placed on system components send information to control card.



Pump elements, distributors and control cards are offered optionally. While ordering a pump, other components have to be ordered separately according to their properties.

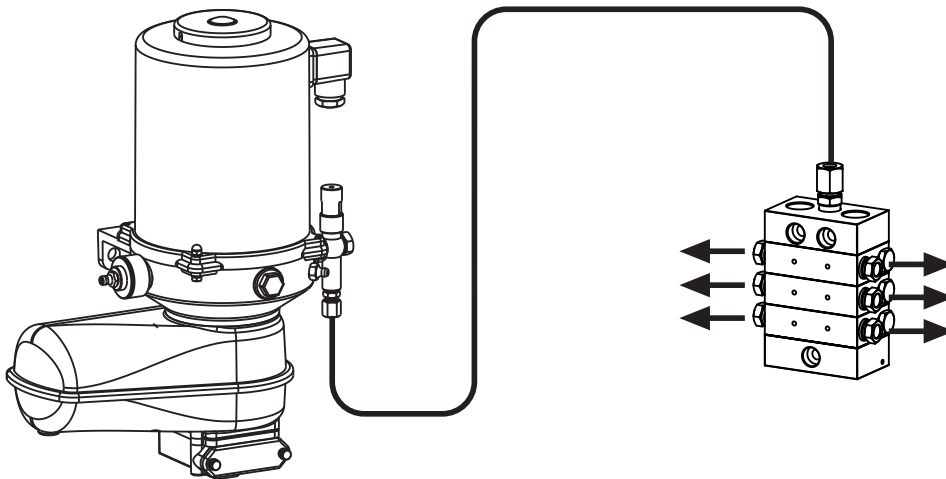

Any maintenance on ALL-1 pumps under electrical voltage could lead to personal injury. Disconnect all electrical power before any maintenance .



Any maintenance on ALL-1 pumps under high pressure could lead to personal injury. Discharge the system pressure before any maintenance .



Unauthorized modifications to the units and the use of unauthorzied spare parts and aids prohibited also disqualify the warranty.

PUMP ELEMENT DESCRIPTION

ALL-1mini grease pumps are available in several displacement volumes. These volumes can be created with pump elements which are optionally offered. 1 to 3 Pump elements can be applied onto ALL-1 mini pump body to take grease out. Even though single pump element can be used as outlet, multiple pump elements can be bridged as single outlet to get more displacement.

Pump element is equipped with security relief valve to protect any damage may occur from high pressure. Lubrication system pressure is increasing when a lubrication point is blocked. Up to 450 bar. pressure, lubrication system's working pressure can be adjusted by security relief valve. Lubricant with over pressure will be out from exhaust hole.

Pump elements are manufactured in 3 types according to displacement amounts. These types can be described as its piston diameter ;

- with Ø5 mm piston, pump element's outlet displacement is 1.5cm³ / minute
- with Ø6 mm piston, pump element's outlet displacement is 2.5cm³ / minute
- with Ø7 mm piston, pump element's outlet displacement is 3.5cm³ / minute

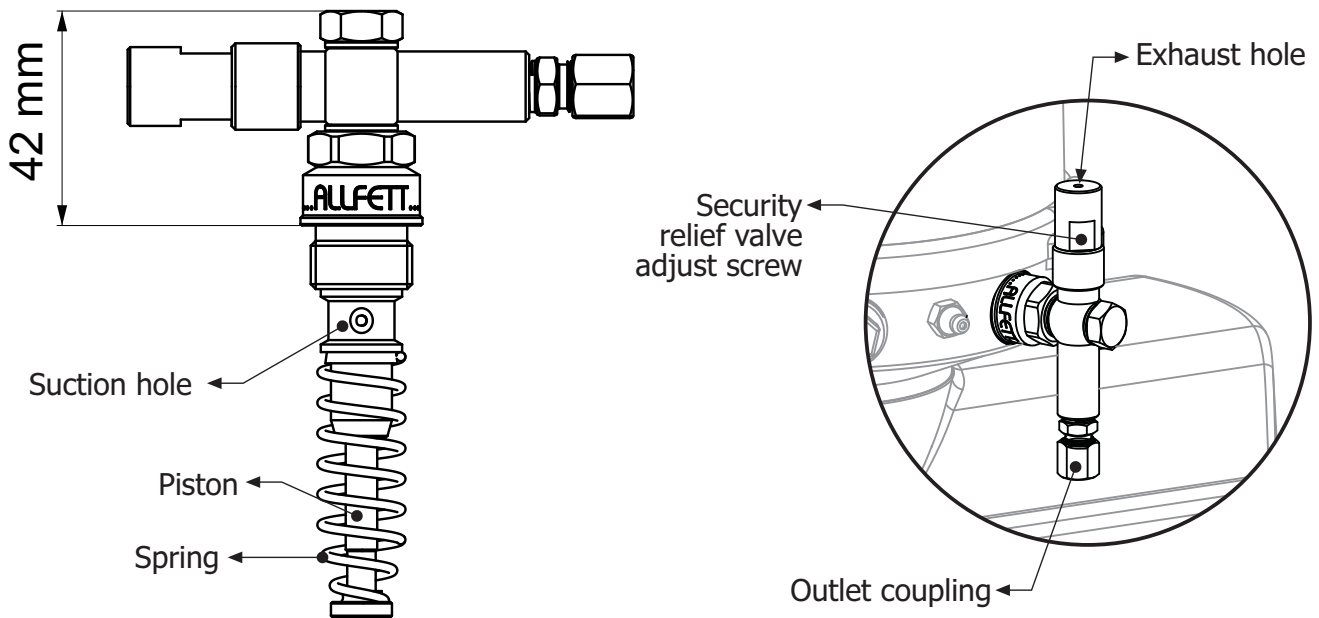

Pump elements are offered optionally. When ordering a pump, pump elements have to be ordered separately according to displacement properties.

LUBRICANT INFORMATION

The properties of grease that can be used with ALLFETT Electric Grease Pumps are described below. The selection of the grease to be used in the system should be made within the following explanations.

1. The grease should have a lithium soap and should include **EP additives** that increase the resistance to high pressure.
2. The NLGI class, which represents the viscosity of the grease, should be used according to the temperature measures that are described in the table below. If there is a significant temperature difference in the environment in which the system is used, the remaining grease in the system must be replaced with the grease that has the correct NLGI class for the said environment.
3. The base oil viscosity of the grease should be between **32-220mm²/s at 40°C** (The structure of grease is similar to of sponges's the higher the base oil viscosity, bigger the volume inside the pores and so, the grease gets thicker.)
4. The grease that will be used should never contain additives such as **molibden, graphite or copper**. Greases that say complex in their descriptions should be investigated. If **Lithium complex** or **Calcium complex** greases are being used, check if they contain molibden, graphite or copper. If they do not contain such additives, use one NLGI class below the recommended NLGI Class by the table below.
5. Different greases with **different NLGI** classes should never be used together. Also liquid oil should never be added to the grease to decrease its viscosity.
6. Different greases with **different soap types** (like lithium or calcium) should never be used together. If mixed, they may cause a chemical reaction. If the grease inside the pump is going to be changed, fully empty the reservoir and only then put the new grease type.
7. The grease which will be filled into the reservoir of the pump should be fully clean from any debris, dirt etc. During filling, no foreign material should get into the reservoir.
8. If a sample of the grease which is going to be used is available, check with your fingers if the grease contains small solid particles. Also the grese should not have sticky properties.

Penetration and NLGI Classes

NLGI classes can be used with ALL-1 pumps are described below. Because of the flow characteristics of grease the NLGI class range should be changed at different weather conditions and also temperature differencies.

for **NLGI 00** grease recomended working temperature is between -30°C and -10°C

for **NLGI 0** grease recomended working temperature is between -10°C and 0°C

for **NLGI 1** grease recomended working temperature is between 0°C and 10°C

for **NLGI 2** grease recomended working temperature is between 10°C and 30°C

for **NLGI 3** grease recomended working temperature is 30°C and over



Lubricant will be used in the system must certainly be clean and any foreign materials must not enter while filling.

LUBRICATION INFORMATION

Grease penetration properties is variable at different environment temperatures. The environmental temperature around lubrication lines must be considered for choosing the correct grease. Grease properties should be appropriate that environmental temperatures. Changing NLGI classes at different temperatures is important to correct lubrication. If necessary, high temperature resistant lubricants should be used in some cases.



It should not be forgotten that the grease penetration properties is variable at different environment temperatures.

PRESSURE LOSE CHART

Loosing pressure in lubrication lines depends on differend variables. The most important variables are pump displacement, environmental temperatures, tube diameter and NLGI class. Each variable must be considered for correct lubrication.

The chart below represents the approximate pressure loose in tube which 1 meter long. Results are varies according to pump element displacement volume created by single or multiple pump elements. Result values are defined in bar.

Tube diameter	Lubricant class	Single Ø6 mm pump element					3 Ø6 mm pump elements				
		2,5 cm ³ / minute					7,5 cm ³ / minute				
		-10°C	0°C	10°C	20°C	30°C	-10°C	0°C	10°C	20°C	30°C
Ø6 x 1 (Ø6mm)	NLGI 0	4,8	2,6	1,4	0,78	0,48	7,8	4,2	2,4	1,44	0,84
	NLGI 1	8	4,4	2,4	1,3	0,8	13	7	4	2,4	1,4
	NLGI 2	12,8	7	3,8	2	1,28	20,8	11,2	6,4	3,84	2,24
Ø8 x 1 (Ø6mm)	NLGI 0	2,7	1,32	0,72	0,42	0,24	3,9	2,1	1,14	0,66	0,42
	NLGI 1	4,5	2,2	1,2	0,7	0,4	6,5	3,5	1,9	1,1	0,7
	NLGI 2	7,2	3,52	1,92	1,12	0,64	10,4	5,6	3	1,76	1,12
Ø10 x 1 (Ø8mm)	NLGI 0	1,44	0,72	0,36	0,21	0,12	2,16	1,1	0,6	0,3	0,18
	NLGI 1	2,4	1,2	0,6	0,35	0,2	3,6	1,8	1	0,5	0,3
	NLGI 2	3,84	1,92	0,96	0,56	0,32	5,76	2,88	1,6	0,8	0,48
Ø12 x 1 (Ø10mm)	NLGI 0	0,96	0,45	0,22	0,12	0,06	1,32	0,66	0,36	0,18	0,1
	NLGI 1	1,6	0,75	0,38	0,2	0,1	2,2	1,1	0,6	0,3	0,18
	NLGI 2	2,56	1,2	0,61	0,32	0,16	3,52	1,76	0,96	0,48	0,29
R 1/2 (Ø15,75mm)	NLGI 0	0,45	0,2	0,09	-	-	0,6	0,27	0,12	0,07	-
	NLGI 1	0,75	0,34	0,16	-	-	1	0,45	0,2	0,12	-
	NLGI 2	1,2	0,54	0,26	-	-	1,6	0,72	0,32	0,19	-
R 3/4 (Ø21,25mm)	NLGI 0						0,33	0,15	0,06	-	-
	NLGI 1						0,55	0,25	0,1	-	-
	NLGI 2						0,88	0,4	0,16	-	-
R 1 (Ø27mm)	NLGI 0										
	NLGI 1										
	NLGI 2										

ELECTRICAL CONNECTIONS of STANDARD TYPE PUMP

Pumps have an electric driven motor. Electrical lines must be connected properly as described in schema below. Electrical socket is placed under motor cover.



Transformer is necessary if there is no " 24 V DC " power source. Use minimum 5A current transformer.

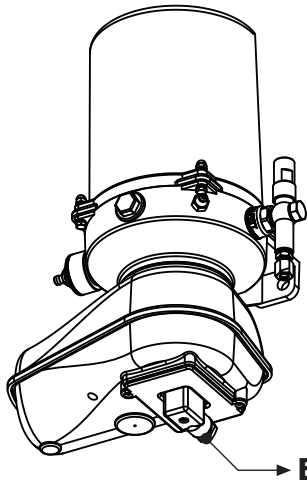

Electrical socket

Electrical socket

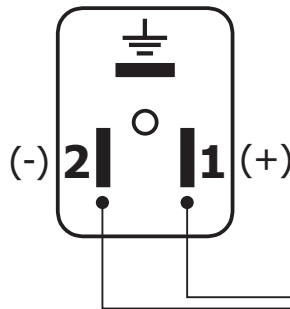

12 - 24 V DC POWER SUPPLY

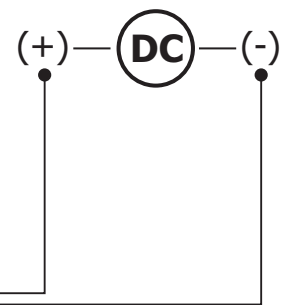

Any maintenance on ALL-1 DC pumps under electrical voltage could lead to personal injury. Disconnect all electrical power before any maintenance .

If ALL-1 DC pump will be used with ALLFETT **EK-9** external control card, electrical lines must be connected properly as described in schema below.

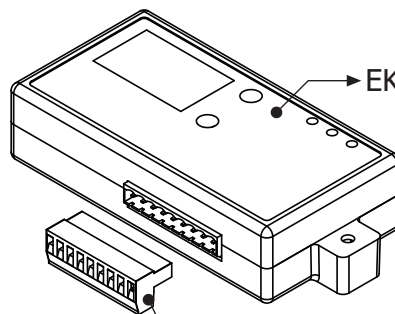

EK-9 external control card

ALL-1 Pump Electrical socket

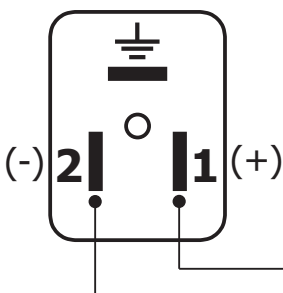

EK-9 Control card socket

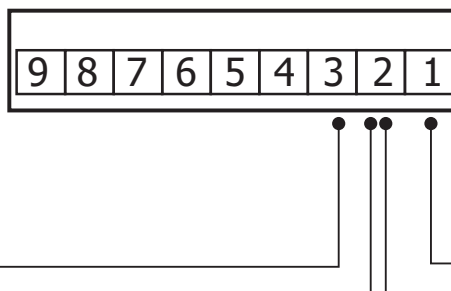

12 - 24 V DC POWER SUPPLY

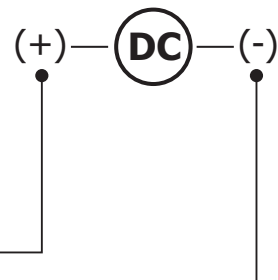

ELECTRICAL CONNECTIONS of INTEGRATED CONTROL CARD TYPE

Pumps have an electric driven motor. Electrical lines must be connected properly as described in schema below. Electrical socket is placed under control card box shown below.

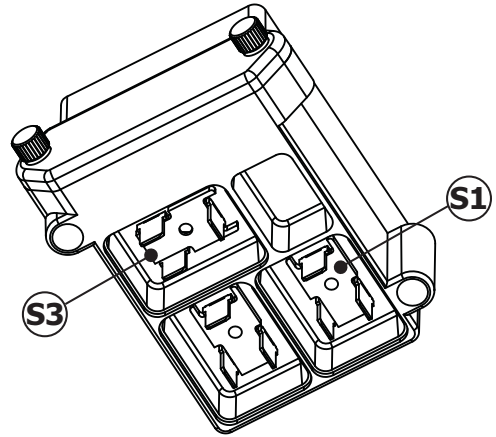
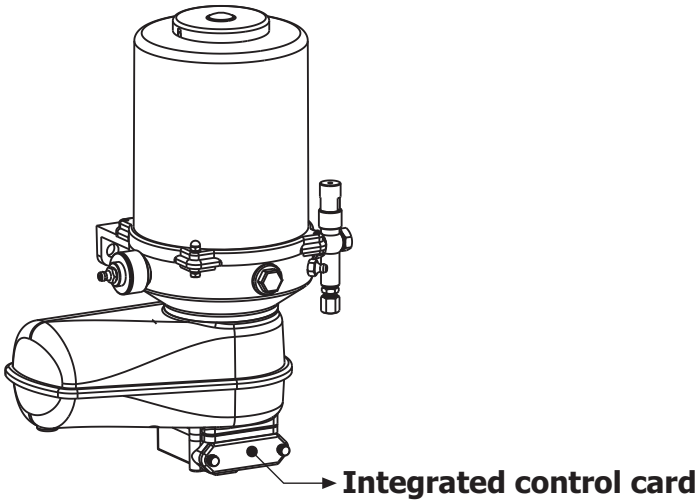

S1 - Standard electrical connection

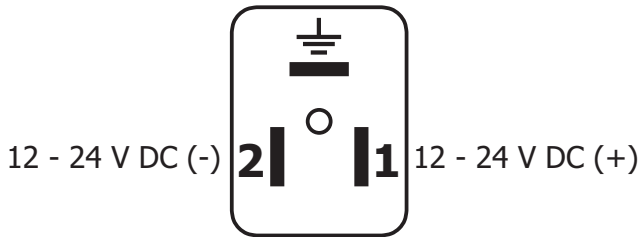

⚡ connection in **S1** socket gives high pressure signal while working time period. In waiting time period, same connection gives ADDITIONAL CYCLE button signal.

S3 - Low Level indicator connection (Optional)

Low level (-)

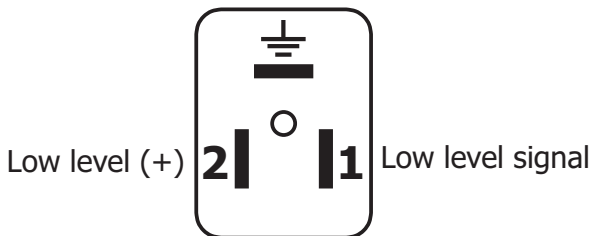

INTEGRATED CONTROL CARD DESCRIPTIONS

CONTROL CARD PANEL

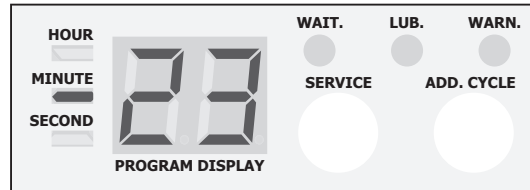

WAIT. : Yellow LED (Waiting)

LUB. : Green LED (Lubricating)

WARN. : Red LED (Warning, Fault)

HOUR : Shows unit of time.

MINUTE : Shows unit of time.

SECOND : Shows unit of time.

PROGRAM DISPLAY : This led shows programming numbers.

SERVICE : Using to start programming.

ADDITIONAL CYCLE : Using to lubricate only one time except the programmed working time. And also using to change numbers while programming.

CONTROL CARD ALARM LIST

Alarms listed below are shown on PROGRAM DISPLAY. While alarm is occurred PROGRAM DISPLAY will be indicating. Also while alarm is occurred warn led will continuously flashing.



A1 : Low level alarm

This alarm is shown if pump out of grease.



A2 : Pressure alarm

This alarm is shown if adjusted pressure reached.



A3 : Motor alarm

This alarm is shown if motor cables are broken or motor fault.



A4 : Fuse broken

This alarm is shown if fuse broken.

INTEGRATED CONTROL CARD PROGRAMMING INSTRUCTIONS

SERVICE and ADDITIONAL CYCLE buttons, where placed onto control card panel, are used for programming control card.

1. Press **SERVICE** Button twice to enter program mode. After entering program mode first digit on program display and green led start to flash. Working time period will be set first.

2. ADDITIONAL CYCLE button changes the numbers shown in flashing digit. Press Additional cycle button until desired number shown in flashing digit. Press **SERVICE** button to save digit.

3. After first digit saved, second digit starts to flash. **ADDITIONAL CYCLE** button changes the numbers shown in flashing digit. Press Additional cycle button until desired number shown in flashing digit. Press **SERVICE** button to save digit.

4. After second digit saved, time unit leds start to flash. **ADDITIONAL CYCLE** button changes the time units. Press Additional cycle button until desired time unit is flashing. Press **SERVICE** button to save time unit.

Working time period is saved and setted. After this section waiting time period will be set.

5. After seting working time unit, first digit on program display and yellow led start to flash. Waiting time period will be set.

6. ADDITIONAL CYCLE button changes the numbers shown in flashing digit. Press Additional cycle button until desired number shown in flashing digit. Press **SERVICE** button to save digit.

7. After first digit saved, second digit starts to flash. **ADDITIONAL CYCLE** button changes the numbers shown in flashing digit. Press Additional cycle button until desired number shown in flashing digit. Press **SERVICE** button to save digit.

8. After second digit saved, time unit leds start to flash. **ADDITIONAL CYCLE** button changes the time units. Press Additional cycle button until desired time unit is flashing. Press **SERVICE** button to save time unit.

Waiting time period is saved and setted. Programming of the Integrated control card is now completed. Integrated control card starts the pump with working time period.

While integrated control card is on, If ADDITIONAL CYCLE button pressed 2 seconds long remaining time period will be shown on program display.



While programming, the time interval for pressing buttons must be in 20 seconds. If 20 seconds passes electronic control card exits from the program menu and operations done before is lost. In this case, card will start to operate with last succesfull programming values.



In case of power breakdown while pump runs at waiting or working time periods, control card will remain it's position before breakdown and resume after power comes. Power breakdown does not make any change on the structure of the previous program.

RULES TO COMPLY WHILE USING AND WARRANTY CONDITIONS

- 1.** Damages occur while additional transports after delivering the goods from ALLFETT to the customer **DISQUALIFIES THE WARRANTY.**
- 2.** Pumps are produced to lubrication purpose only and are not convenient to work more than 2 hours continuously. Working under maximum pressure more than 2 hours will harm the system. Damages occur from this reason **DISQUALIFIES THE WARRANTY.**
- 3.** Washing of the pump with pressured water causes damage. Any damage occur from this reason **DISQUALIFIES THE WARRANTY.**
- 4.** Pump reservoir is made of transparent material to see grease level. Painting any part of the pump is not recommended. Any painted parts **DISQUALIFY THE WARRANTY.**
- 5.** Pumps have an electric driven motor. Electrical lines must be connected properly as described in PAGE 10 - 11 and applied only by qualified and instructed personel.
- 6.** All electrical connections and lines must be checked regularly for damage and to ensure that they are firmly in place.
- 7.** Damages coming from voltage fluctuation, wrong electricity installation, connecting wrong voltage to product **DISQUALIFIES THE WARRANTY.**
- 8.** Keeping an uncovered cable(s) during system assembly may cause fatal damages where high voltage is transformed to low voltage. Lines must be connected properly to prevent personal injury and damage to property.
- 9.** Transformer is necessary if there is no " 24 V DC " electrical source. Use minimum 5A current transformer.
- 10.** Only proper NLGI class lubricants must be used with in system. NLGI class must be changed according to weather conditions. Use NLGI 0 for cold weather, increase the NLGI class up to 3 towards hot weathers.
- 11.** Only LITHIUM based and EP additive lubricants must be used with in system.
- 12.** Rubber based lubricant types must not be used in the system. Damages or faults occur from this reason **DISQUALIFIES THE WARRANTY.**
- 13.** Lubricant will be used in the system must certainly be clean and any foreign materials must not enter while filling.
- 14.** Any foreign materials, dirt or small particules while filling lead to system units failing and possibly property damage to equipments. Damages or faults occur from this reason **DISQUALIFIES THE WARRANTY.**
- 15.** Pump must be filled from the grease nipple. If grease level is lower than the minimum level (as you can not see grease level) grease nipple must be used to prevent air entrance inside the pomp body. Lockable filling cover option can only be used after filling pump from grease nipple up to minimum level.

RULES TO COMPLY WHILE USING AND WARRANTY CONDITIONS

- 16.** If lockable filling cover will be used to fill pump, environment must be clean to avoid any foreign materials entering to reservoir. Any foreign materials, dirt or small particules while filling lead to system units failing and possibly property damage. Damages or faults occur from this reason **DISQUALIFIES THE WARRANTY.**
- 17.** If the pump works without lubricant, pump elements will send air to the points instead of grease. Because of that any points connected to pump will not get any lubricant. Damages on pump and on the system coming from that reason **DISQUALIFIES THE WARRANTY.**
- 18.** Using ALL-1 pumps with integrated control card models, high frequency wireless comination devices 1 meter distance from the pump may cause malfunction. Damages or faults occur from this reason **DISQUALIFIES THE WARRANTY.**
- 19.** Integrated control card works between 10 to 30 Voltage. Although there is a protection against high voltage, control card may be broken if connected to high voltage power source. Damages or faults occur from this reason **DISQUALIFIES THE WARRANTY.**
- 20.** Disassembling or loosing any part while pump working is prohibited. Any damage coming from this reason **DISQUALIFIES THE WARRANTY.** Also any personal injury occur from this reason ALLFETT does not accept responsibility.
- 21.** Another goal of Centralized Lubrication Systems is to protect environment. So it is advised to fill grease to the systems by mobile or hand pumps.
- 22.** Unauthorized modifications to the units and the use of unauthorzied spare parts and aids prohobited and **DISQUALIFIES THE WARRANTY.** Only maintenance may apply descibed in PAGE 14 - 15. ALLFETT Technical Service must be informed to any other possible troubles and necessary procedures must be performed.
- 23.** ALLFETT Mekanik ve Elektronik Sistemler SAN. TIC. LTD. STI and ALLFETT Pazarlama ve Dis Ticaret LTD. STI. does not accept responsibility for damages described in items above on equipments which ALLFETT systems are installed.

QUALITY SYSTEM



This product is produced by **ALLFETT Mekanik ve Elektronik Sistemler San. Tic. Ltd. Sti.** company, which, is certificated by Bureau Veritas with certificate to compatible for ISO 9001:2008 standard and owner of the quality management system.

PUMP MAINTENANCE

1. IF PUMP NOT STARTS

- a. Electrical connections of the pump may be loosen or broken. Check the electrical cables and connections of the system according to schemas on page 9 and page 10.
- b. Connected electricity to pump may different then " DC " voltage. Connect the electricity 12 or 24 V DC which is marked on pump sticker.
- c. Connected electricity may be converted to "DC" voltage from "AC" voltage by a transformer.

Transformer must be minimum 5A current.

- d. If pump has low level indicator ;

Control unit (PLC or integrated control card) may give failure and stops the pump because of the grease inside pump decreased under minimum level. Fill the reservoir according to items 10, 11, 12, 13, 14, 15 and 16 in RULES TO COMPLY WHILE USING AND WARRANTY CONDITIONS.

- e. If ALLFETT control card is connected the system ;

Electronic control card may be in waiting period. Wait until working time starts.

If necessary control card pass to working period by pressing **ADDITIONAL CYCLE** button.

2. IF PUMP NOT SENDING GREASE

- a. Grease inside pump decreased under minimum level. Fill the reservoir according to items 10, 11, 12, 13, 14, 15 and 16 in RULES TO COMPLY WHILE USING AND WARRANTY CONDITIONS.
- b. Pump elements may take air due to work without grease ;

Read and apply PUMP ELEMENT MAINTENANCE information on page 14.



Unauthorized modifications to the units and the use of unauthorized spare parts and aids prohibited and disqualify the warranty.

TECHNICAL SERVICE

ALLFETT MEKANİK VE ELEKTRONİK SİSTEMLER SAN. VE TİC. LTD. ŞTİ.
Yeni Eyüp Bulvarı, Topçular Caddesi, Set Üstü, No:1 Demirkapı-Rami / İstanbul
Telefon: 0 212 501 32 01 (PBX) www.allfett.net
Fax : 0 212 501 33 37 info@allfett.net

PUMP ELEMENT MAINTENANCE

First use of the pump after filling reservoir, air must be sent out from pump element(s). To do this operation please read description below ;



Filling the pump must be done by grease nipple on pump body.

Remove connected tube from pump element's outlet coupling. Loosen pump element from pump body for 2 - 3 turns. Start to operate pump. When grease coming from around pump element body, tighten again pump element body to pump. Pump should run continuously until grease without air is seen from pump element outlet. When the grease without air is seen from pump element outlet, coupling must be tightened to outlet again

With this process pump element is now ready to send grease to lubrication point. Grease coming out from end point of lubrication line may take long time according to line length.

If problems may appear while operate ;

- a. Pump element's piston spring may be broken. Remove the pump element and spring carefully. Pay attention spring does not fall into body. Change the spring if necessary.
- b. Pump element's piston may be blocked. Remove the pump element and clean with diesel based liquid. Assemble it to the pump body after drying with pressurized air.
- c. Sealing ring inside the pump element's check-valve may be worn or damaged. Change the sealing ring.
- d. Grease may be seen coming out from the security valve discharge. This means there is a blockage in lubrication point or distributor connected to this pump element. Blockage may cause the system to reach very high pressures and cause explosion of the lubrication lines. Blockage must be identified and fixed.

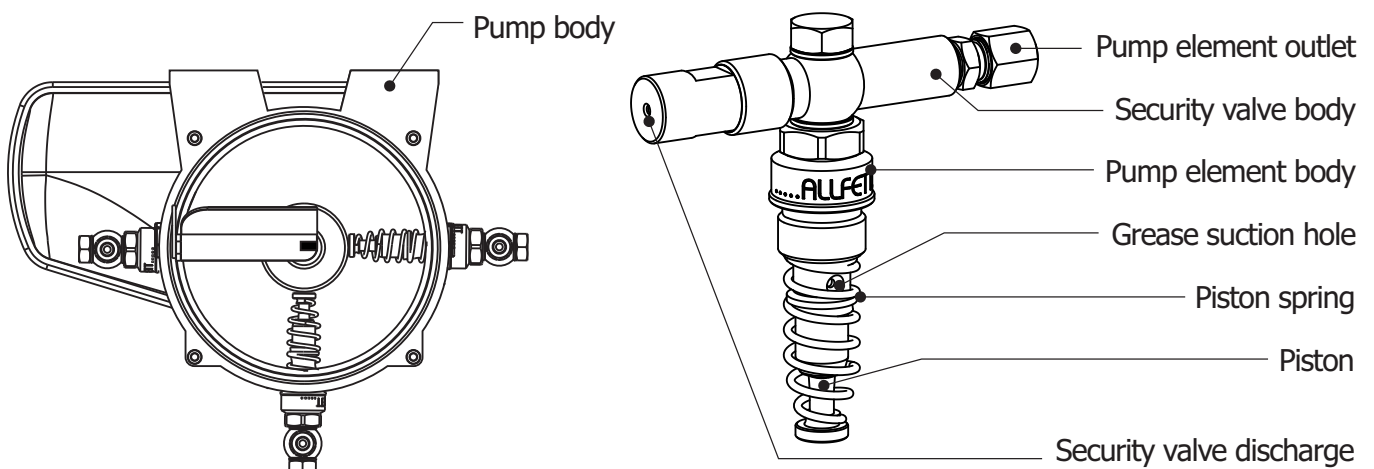

ALL-1 pump body is suitable for 1 and up to 6 pump elements.

ORDER INFORMATION

Product name - description	Order number
ALL-1mini standard pump - 12 V DC - 1 Lt.	20 12 01 A1
ALL-1mini standard pump - 12 V DC - 1.8 Lt.	20 12 18 A1
ALL-1mini standard pump - 24 V DC - 1 Lt.	20 24 01 A1
ALL-1mini standard pump - 24 V DC - 1.8 Lt.	20 24 18 A1
ALL-1mini Integrated control type pump - 12 V DC - 1 Lt.	20 12 01 EC
ALL-1mini Integrated control type pump - 12 V DC - 1.8 Lt.	20 12 18 EC
ALL-1mini Integrated control type pump - 24 V DC - 1 Lt.	20 24 01 EC
ALL-1mini Integrated control type pump - 24 V DC - 1.8 Lt.	20 24 18 EC

OPTIONAL COMPONENTS

Product name - description	Order number
ALL-1 Pump element - Ø5	10 00 05 02
ALL-1 Pump element - Ø6	10 00 06 02
ALL-1 Pump element - Ø7	10 00 07 02
Filling filter - Type Small	10 0260
Filling filter - Type Big	10 0261
Motor - 12 V DC	10 12 MT 01
Motor - 24 V DC	10 24 MT 01

SALES

ALLFETT PAZARLAMA VE DIŐ TİCARET LTD. ŐTİ.

Yeni Eyüp Bulvarı, Topçular Caddesi, Set Üstü, No:1 Demirkapı-Rami / İstanbul
 Telefon: 0 212 501 32 01 (PBX) www.allfett.net
 Fax : 0 212 501 33 37 info@allfett.net

WARRANTY

Utilisation of this warranty certificate has been permitted by The Republic of Turkey, The Ministry of Industrial and Commerce, The general Administration of Protection of Consumer Right and Competition, in accordance with the law numbered 4077 .

PRODUCER COMPANY

NAME : ALLFETT Mekanik ve Elektronik Sistemler
San. ve Tic. Ltd. Şti.
CENTRAL ADDRESS : Yeni Eyup Bulvari, Topcular Cad. Set Ustu, No:1 Demirkapı-
Rami / İstanbul
TELEPHONE : 0212 501 32 01 (PBX)
FAX : 0212 501 33 37

AUTHORISED PERSON

SIGNATURE - STAMP : :

PRODUCT

TYPE : Electrical grease pump
BRAND : ALLFETT
MODEL : ALL-1mini Standard
ALL-1mini With integrated control
SERIAL NUMBER :
DELIVERY DATE / PLACE :
WARRANTY : 2 years
REPAIR TIME : 30 days

SALER COMPANY

NAME :
CENTRAL ADDRESS :
TELEPHONE :
FAX :
BILL DATE / NUMBER :

WARRANTY CONDITIONS

1. The warranty period is two years from the date of delivery.
2. The product including all its components is under the warranty of our company.
3. In case of defects within the warranty period the period spent in repairing is added to the warranty period. The repairing period is maximum 30 days. This period starts from the date of delivery of the product to the services centers or to the seller, the agency the representative, the importer or the manufacturer of the product respectively, in case there are service centers.
4. In case the product has material, workmanship or manufacturing defects, the product will be repaired free of charge and expenses of any sort including labor, the value of the parts replaced or any our charges.
5. The product will be replaced free of charge;
 - If the product permanently disfunctions due to repeating the same defect more than four times within the warranty period
 - If the maximum period for repairing is exceeded.
 - If it is determined that the defect cannot be repaired by report written by the service, or in the absence of service centers, by the seller, agency, representative, importer or manufacturer of the product respectively.
6. The present warranty does not cover damages resulting from importer handling by deviating from the instructions in the manual.
7. General administration of protection of consumer rights and competition in the ministry of industry and commerce may be applied for problems concerning the warranty certificate.

DANGEROUS OR HARMFUL CONDITIONS TO ENVIRONMENTAL AND HUMAN HEALTH DURING USE

All ALLFETT systems are producing according to relevant provisions of security regulations. There is no risk for environmental and human health during use.

TRANSPORT AND STORAGE

There are no restrictions on transportation by land, air and sea. In general, products should be stored in a dry and dust-free environment. The storage temperatures are between -10°C and +40°C.

All products are packed with paper based support material to reduce damage. Upon receiving the package please check the items for possible damage.



ALLFETT MEKANİK VE ELEKTRONİK SİSTEMLER SAN. VE TİC. LTD. ŞTİ.

Topçular Mahallesi, Topçular Caddesi No:1/1 - Eyüp / İstanbul

Telefon : 0 212 501 32 01 (PBX)

www.allfett.net

Fax : 0 212 501 33 37

info@allfett.net